

RivetLab

RT-512

Ratchet Rivnut Tool for Rivet Nuts up to M12

The RivetLab® RT-512 is a professional standard heavy duty hand rivnut tool. It is capable of setting rivet nuts from M5 to M12 in all materials and rivstuds from M5 to M8.

Setting Capacity

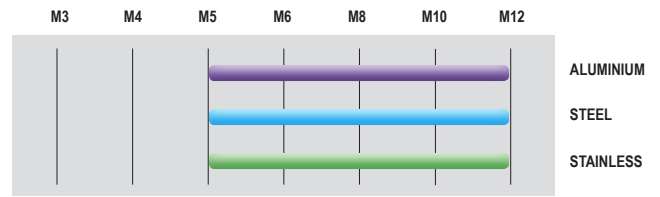

Fast and simple change of mandrel and nosepiece

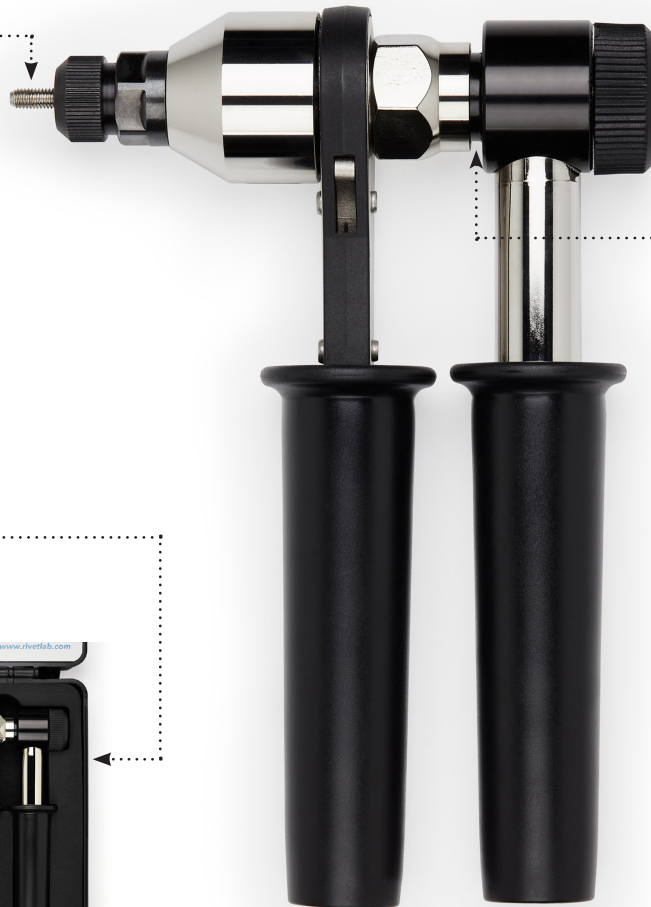

Laser engraved stroke gauge to assist with blind rivet nut setting

Supplied in a carry case with M5-M12 nose assemblies for rivet nuts & M5-M8 mandrels for rivstuds



Scan the QR code for a demo video of the RT-512 rivnut tool

Specifications

Product Code:	RT-512-KIT
Weight:	1.1 kg
Length:	150 mm
Height:	205 mm
Stroke (max.):	7 mm

Package Accessories

Mandrels and nosepieces for M5, M6, M8, M10 & M12 rivet nuts
Mandrels for M5, M6 & M8 rivstuds
Mandrels and nosepieces UNC are available
Operating Manual

* Dimensions and specifications are subject to change without notice. Check your distributor for the latest data sheet.

Unit 4, 28 Barcoo St., Roseville, NSW 2069
PH: 02 9882 1112

www.rivetlab.com